

ZDRS-775BM-7715-F

Typical Applications:

- Precision Instruments
- Automatic Vending Machines
- Household Appliances
- Tooth Brushes
- Office Automation Equipments
- Electronic Typewriter

DIRECTION OF ROTATION

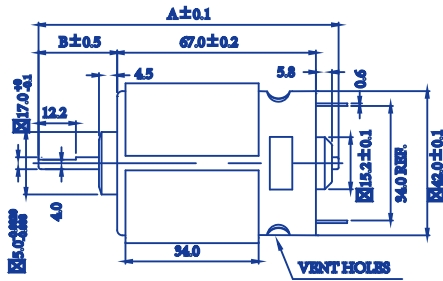
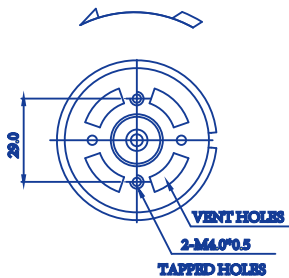

UNIT: MILLIMETERS

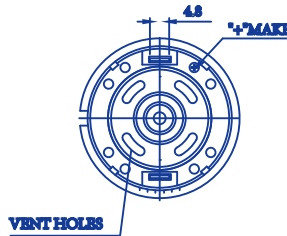

NOTES:

- LENGTH OF SHAFT DIM "A" IS 134.0mm
- FRONT EXTENSION DIM "B" IS: mm 19.2
MEASURED WITH SHAFT PUSHED TO PLASTIC END CAP
- BACK PLAY max Max.
- DIRECTION OF ROTATION: ANTI-CLOCKWISE
WHEN VIEWING MOTOR OUTPUT END WITH POSITIVE VOLTAGE APPLIED TO POSITIVE TERMINAL

TEST CONDITION:

- RATED VOLTAGE : VDC 18.0
- OPERATING TEMPERATURE RANGE: °C — °C

60

AT NO LOAD:

- CURRENT : A MAX
- SPEED : rpm 19800 ± 10%

AT MAXIMUM EFFICIENCY:

- CURRENT : A 10.4
- OUTPUT : W 159
- SPEED : rpm 16614
- TORQUE : g.cm 96.8
- EFFICIENCY: % 85

AT STALL:

- CURRENT : A 54.4
- TORQUE : g.cm 5823

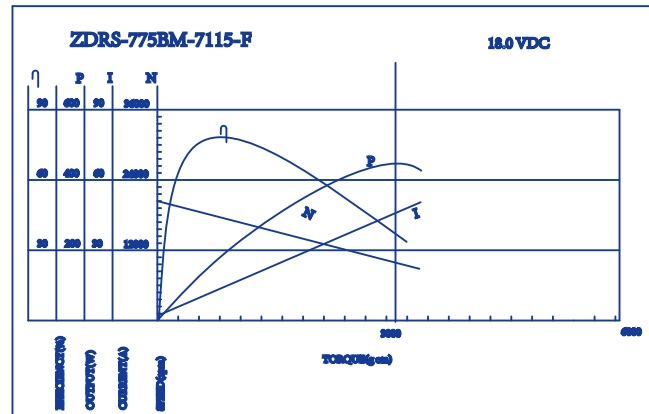

CUSTOMER NO.		DRAW BY		CHECKED BY	T.Z	APPROVED BY		DATE	
--------------	--	---------	--	------------	-----	-------------	--	------	--