

RS-555 SH/SA

Application:

Vacuum Cleaner, Air Compressor / Drill & Screwdriver / Cordless Garden Tool, Radio Control Model, Massager.



Electrical Specification

Model	Voltage		No Load		At Maximum Efficiency				Stall			
	Operating Range	Nominal	Speed	Current	Speed	Current	Torque		Output	Torque		Current
			r/min	A	r/min	A	mN·m	g·cm	w	mN·m	g·cm	A
RS555-SH-4033	DC 6-18V	DC 12V	8000	0.35	6980	1.79	22.5	230.5	16.6	181.3	1850	14.9
RS-555SH-2770	DC 18-30V	DC 24V	9100	0.18	7700	1.22	27.9	285	22.7	195.6	1995	7.5
RS-555SH-5022	DC 6-12V	DC 6V	7000	0.68	6000	3.7	29.4	300	18.2	196	2000	20.9
RS-555SA-4525	DC 3-9V	DC 6V	6000	0.4	5000	2.3	21.6	220	11.5	143.7	1466	13
RS-555SA-2755	DC 6-18V	DC 12V	5300	0.17	4400	1.2	19.2	200	9.3	130.7	1333	7.1
RS-555SA-3348	DC 18-30V	DC 24V	11400	0.25	10100	1.67	30.4	310.9	32.71	306.4	3130	17.32

*Note: It's only typical technical data for reference, Special requirement can be customized.

Mechanical Dimensions

RS-555SH

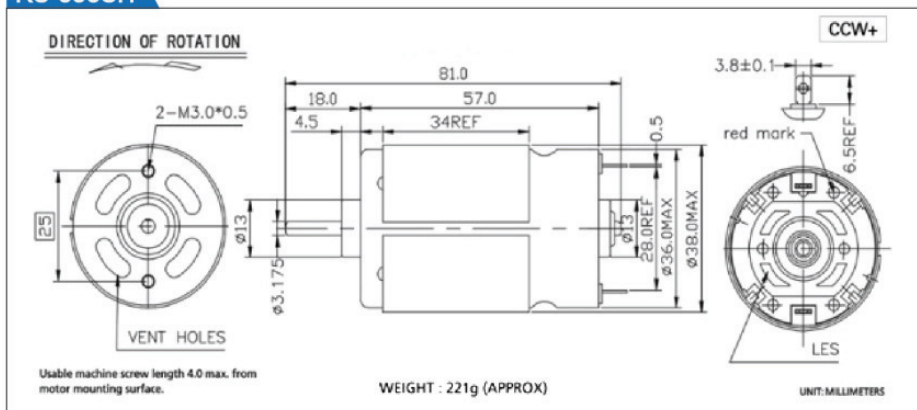

RS-555SA

