

RS-545 RH/SH/SA

Application:

Vacuum Cleaner, Air Compressor / Drill & Screwdriver / Cordless Garden Tool, Radio Control Model, Massager.



Electrical Specification

Model	Voltage		No Load		At Maximum Efficiency					Stall		
	Operating Range	Nominal	Speed	Current	Speed	Current	Torque		Output	Torque		Current
			r/min	A	r/min	A	mN·m	g·cm	w	mN·m	g·cm	A
RS-545RH-4522	3.6-12.0	DC 12V	27800	1.3	22940	6.14	19.4	198	46.5	111	1130	29
RS-545RH-5018	4.5-12.0	DC 12V	24000	1.3	20510	7.65	31.1	317	66.7	214	2180	45
RS-545RH-18150	12-32	DC 24V	5600	0.12	4560	0.53	16.4	167	7.82	88.2	900	2.3
RS-545RH-22100	12-34	DC 12V	4200	0.16	3350	0.63	12.5	127	4.36	61.7	630	2.5
RS-545SH-4075	DC 9-15V	DC 12V	9300	0.4	7500	1.8	15.3	157	12.1	79.3	810	7.62
RS-545SH-22105	DC 12-32V	DC 24V	6500	0.16	5648	0.72	22	224.6	12.8	136.2	1390	4.8
RS-545SA-2485	DC 9-15V	DC 12V	5100	0.17	3900	0.75	12.7	130	5.2	52.9	540	2.6

*Note: It's only typical technical data for reference, Special requirement can be customized.

Mechanical Dimensions

RS-545SH

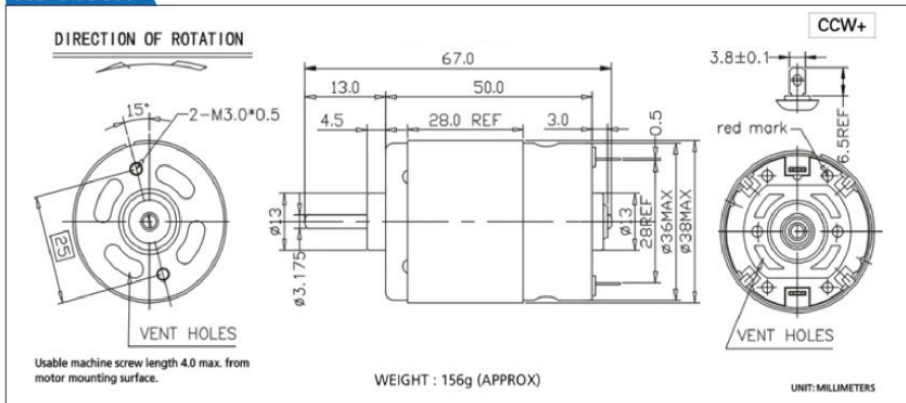

RS-545SA

