

# RS-380 SH/SA

## Application:

Vacuum Cleaner Kitchen Appliance、 Cordless Power Tools: Drill & Screwdriver、 Water pump。



## Electrical Specification

Model	Voltage		No Load		At Maximum Efficiency					Stall		
	Operating Range	Nominal	Speed	Current	Speed	Current	Torque		Output	Torque		Current
			r/min	A	r/min	A	mN·m	g·cm	w	mN·m	g·cm	A
RS-380SH-4045	DC 3-9V	DC 7.2V	16200	0.5	14060	3.29	10.9	111	16	82.3	840	21.6
RS-380SH-3557	DC 12-24V	DC 12V	21200	0.44	18367	2.85	11.26	114.9	21.68	84.2	860	18.5
RS-380SH-3750	DC 6-12V	DC 12V	16500	0.45	13966	1.96	8.34	85.2	12.67	68.6	700	14.67
RS-380SH-12300	DC 12-30V	DC 24V	8000	0.07	6540	0.31	6.27	63.9	4.29	34.3	350	1.4
RS-380SA-3270	DC 3-12V	DC 6V	9200	0.26	7800	1.4	7.4	75	6	48.4	493	7.8
RS-380SA-12350	DC 12-28V	DC 24V	7400	0.06	6000	0.27	6.3	64	3.9	33.1	338	1.2

\*Note: It's only typical technical data for reference, Special requirement can be customized.

## Mechanical Dimensions

### RS-380SH

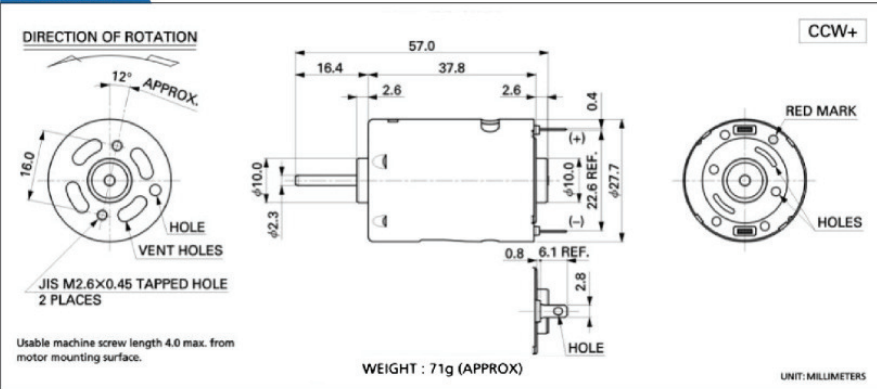

### RS-380SA

