

Ultimag® Size 5EM

Part Number: 199173-0XX

All catalogue products manufactured after April 1, 2006 are RoHS Compliant

Specifications

Dielectric Strength	1000 VRMS (23 awg); 1200 VRMS (24-33 awg)
Recommended Minimum Heat Sink	Maximum watts dissipated by the Ultimag are based on an unrestricted flow of air at 20°C, with the Ultimag mounted on the equivalent of an aluminium plate measuring 19.1 cm square x 0.32 cm thick
Thermal Resistance	5.36°C/watt with heatsink; 12.9°C/watt without heatsink
Rotor Inertia	3.085 x 10 ⁻⁶ kgm ²
Peak Torque Rating (Tp)	0.7 Nm
Power Input	210 watts (stalled at Tp: 25°C; Pp)
Number of Phases	1
Static Friction (Tf)	7 mNm
-3dB Closed Loop	66.5 Hz
Maximum Winding	180°C
Number of Poles	6
Weight:	363 gms
Dimensions:	Ø49.2 mm x 31.75 mm L max (See page B10)



Performance

Maximum Duty Cycle*	100%	50%	25%	10%
K _M (mNm/√watt)	76.3	84.6	57.4	48.3
Maximum ON Time (sec) when pulsed continuously ¹	∞	40	15	4
Maximum ON Time (sec) for single pulse ²	∞	109	36	10
Typical Energise Time (msec) ³	6.0	5.5	4.5	4.0
Watts (@ 20°C)	21	42	84	210
Ampere Turns (@ 20°C)	621	878	1242	1964

Coil Data

awg (0XX) ⁴	Resistance (@20°C)	# Turns ⁵	VDC (Nom)	VDC (Nom)	VDC (Nom)	VDC (Nom)
23	1.05	128	4.7	6.6	9.4	14.8
24	2.24	213	6.9	9.7	13.7	21.7
25	3.16	240	8.1	11.5	16.3	25.8
26	4.45	270	9.7	13.7	19.3	30.6
27	8.50	404	13.4	18.9	26.7	42.2
28	11.90	452	15.8	22.3	31.6	50.0
29	21.10	630	21.0	29.7	42.1	67.0
30	29.50	705	24.9	35.2	49.8	78.7
31	50.30	948	32.5	45.9	65.0	103.0
32	82.70	1232	41.7	58.9	83.0	132.0
33	134.00	1576	53.0	74.9	106.0	168.0

*Not recommended for full stroke at 100% duty cycle.

How to Order

Add the coil awg number (0XX) to the part number (for example: to order a 25% duty cycle rated at 26.7 VDC, specify 199173-027).

Please see www.ledex.com (click on Stock Products tab) for our list of stock products available through our distributors.

- ¹ Continuously pulsed at stated watts and duty cycle
- ² Single pulse at stated watts (with coil at ambient room temperature 20°C)
- ³ Typical energise time based on no load condition. Times shown are for half of full rotary stroke starting at centre-off position.
- ⁴ Other coil awg sizes available — please consult factory
- ⁵ Reference number of turns

WARNING: Exposed Magnet may affect pacemakers. In the event a product unit's magnet is exposed due to product disassembly, Pacemaker Wearers should distance themselves 3 metres from exposed magnet.

All specifications subject to change without notice.

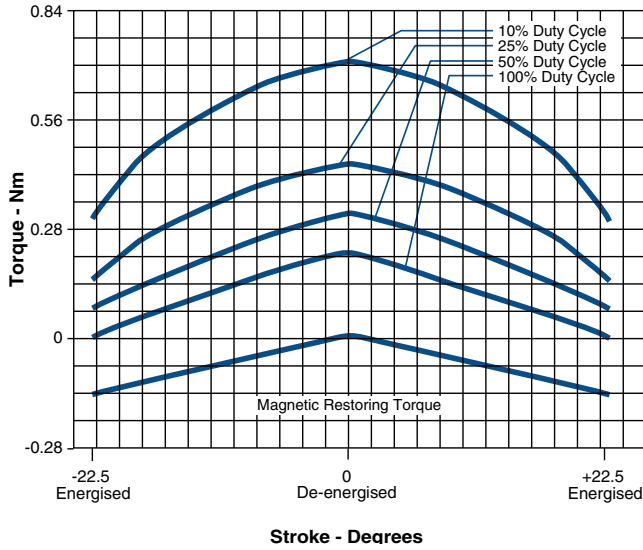

Graph 1 shows three position operation. In any mode, the armature seeks centre of stroke at zero power. Applying a positive or negative voltage causes the shaft to rotate clockwise or counter clockwise. When power is removed, the restoring torque is applied to the load, or alternatively, the shaft can be driven to centre under power.

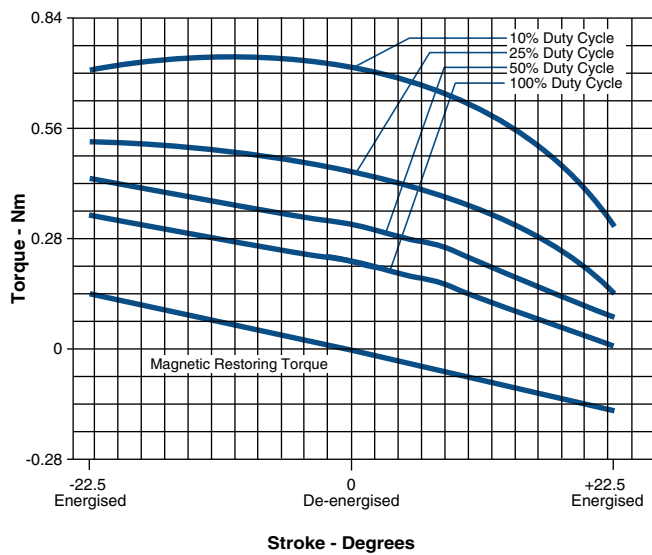

Graph 2 shows operation end-to-end. Note the high starting torque for high starting acceleration or for stopping the load by means of reverse voltage at the end of the stroke. If the device is used in a full stroke application, the load can be externally latched, detented, or biased to either end of stroke.

NOTE: The Size 5EM Ultimag is not recommended for full stroke operation at 100% duty cycle.

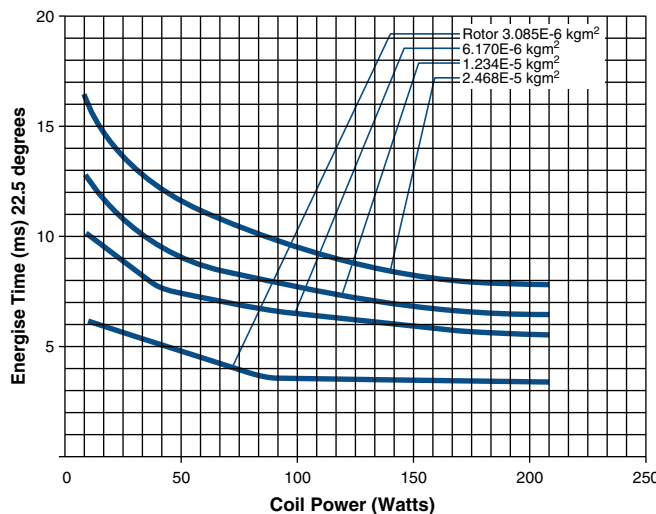

Graph 3 shows how speed varies with load. Each curve represents a different inertial load, which is a multiple of the armature inertia.

Calculate the inertia of your system, then use this chart to determine Ultimag speed in your application. Inertia determination of simple shapes is shown in most engineering handbooks; complex shapes are calculated in solid modeling software or are measured empirically. This graph represents half of the full rotary stroke starting at the centre-off position.

Ultimag[®] Dimensions

ROTARY Ultimag[®]

mm

4EM

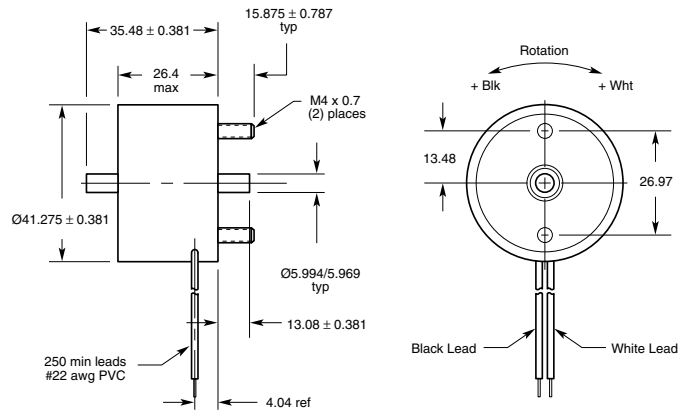

5EM

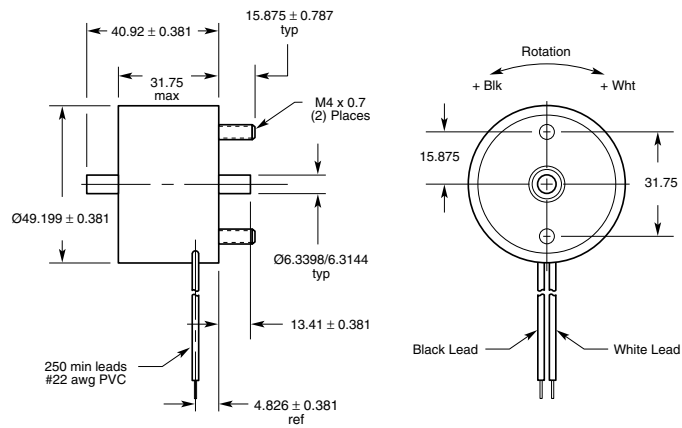

6EM

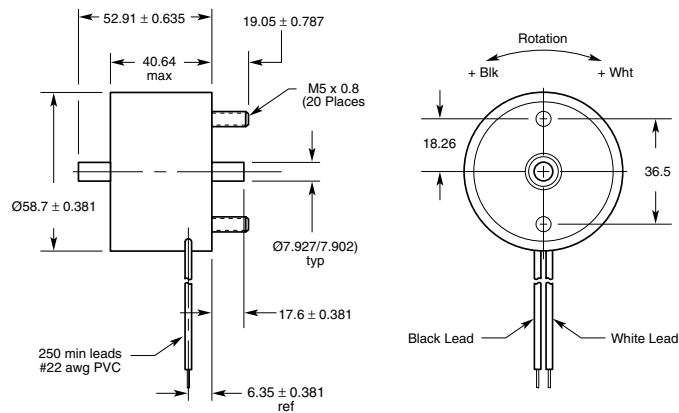

All specifications subject to change without notice.