

# Ledex® Rotary Solenoids Size 5B Bobbin Coil

## Performance Specifications

Stroke	Holding Torque <sup>2</sup> (mNm)	Starting Torque (mNm) <sup>1</sup> @ 20°C Maximum Duty Cycle				
		100%	50%	25%	10%	5%
25°	452.0	203.4	395.5	655.4	937.9	1130.0
35°	**	101.7	237.3	463.3	779.7	937.9
45°	339.0	79.1	192.1	361.6	565.0	678.0
67½°	*	56.5	124.3	226.0	372.9	452.0
95°	226.0	22.6	45.2	101.7	180.8	214.7

All data is at 20°C coil temperature. Force (torque) outputs degrade with elevated temperatures.

<sup>1</sup> Gross starting torques are shown. For net available starting torque, subtract return spring torque of 28.2 mNm ±20%.

<sup>2</sup> Holding torque is shown at the stabilised temperature of 105°C and continuous duty.

\* Consult factory.

## How to Order

- Using the Performance Chart to the left, select one of the five columns which provides the appropriate duty cycle for your application. Reading down this column locate the torque for the stroke you need. For net available starting torque, subtract return spring torque of 28.2 mNm ±20% (if torque is insufficient go to next larger solenoid size).
- Use the chart below to select the model number corresponding to your desired design, stroke and direction of rotation (as viewed from armature end, opposite mounting studs).
- Using the Specification Chart to the right, select the same duty cycle column. Follow down the column into the VDC ratings. Select the voltage which most closely matches your supply voltage. Read across to the left to select the coil awg suffix.
- Replace the last two digits of the model number (XX) with the coil awg number to complete the part number.

Please see [www.ledex.com](http://www.ledex.com) (click on Stock Products tab) for our list of stock products available through our distributors.

All catalogue products manufactured after April 1, 2006 are RoHS Compliant

ROTARY Solenoids

- Armature cover
- Base end shaft
- Return spring

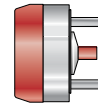

Stroke/ Direction*	Nom. Axial Stroke	
25° CW	1.1 mm	910-380-5XX
25° CCW	1.1 mm	910-385-5XX
35° CW	1.1 mm	910-381-5XX
35° CCW	1.1 mm	910-386-5XX
45° CW	1.1 mm	910-382-5XX
45° CCW	1.1 mm	910-387-5XX
67½° CW	1.3 mm	910-383-5XX
67½° CCW	1.3 mm	910-388-5XX
95° CW	1.4 mm	910-384-5XX
95° CCW	1.4 mm	910-389-5XX

\* Direction of rotation (cw – clockwise or ccw – counterclockwise) is viewed from the armature end of the solenoid opposite the mounting studs.

Note: The XX in the part number suffix must be filled in with the awg of your choice.

# Ledex® Rotary Solenoids Size 5B Bobbin Coil

## Coil Specifications

Maximum Duty Cycle	100%	50%	25%	10%	5%
Maximum ON Time (sec) when pulsed continuously <sup>1</sup>	∞	100	36	10	3.5
Maximum ON Time (sec) for single pulse <sup>2</sup>	∞	160	44	13	4.6
Watts (@ 20°C)	21	42	84	210	420
Ampere Turns (@ 20°C)	890	1250	1760	2800	3987

### Coil Data

awg (0XX) <sup>3</sup>	Resistance (@20°C)	# Turns <sup>4</sup>	VDC (Nom)	VDC (Nom)	VDC (Nom)	VDC (Nom)	VDC (Nom)
23	2.01	294	6.1	8.5	12.0	19.1	27.0
24	3.15	364	7.7	10.8	15.2	24.0	35.0
25	4.88	448	9.7	13.6	19.2	31.0	43.0
26	7.72	564	12.2	17.1	24.0	38.0	55.0
27	10.90	648	15.0	21.0	30.0	47.0	67.0
28	18.20	836	19.4	27.0	38.0	61.0	87.0
29	30.40	1105	25.0	34.0	48.0	77.0	110.0
30	42.50	1248	30.0	43.0	60.0	95.0	136.0
31	69.00	1590	39.0	54.0	76.0	122.0	173.0
32	107.00	2006	48.0	67.0	94.0	149.0	213.0
33	169.00	2470	61.0	86.0	120.0	192.0	273.0

## General Specifications

Dielectric Strength	23 awg, 1000 VRMS; 24-33 awg, 1200 VRMS
Recommended Minimum Heat Sink	Maximum watts dissipated by solenoid are based on an unrestricted flow of air at 20°C, with solenoid mounted on the equivalent of an aluminium plate measuring 90.5 mm square by 3.2 mm thick.
Coil Resistance	±10% tolerance
Starting Torque	Gross torque values are shown. For net starting torque, subtract return spring torque
Return Spring Torque	28.2 mNm ±20%
Weight	283.5 g
Dimensions	See page D33

- <sup>1</sup> Continuously pulsed at stated watts and duty cycle.
- <sup>2</sup> Single pulse at stated watts (with coil at ambient room temperature 20°C).
- <sup>3</sup> Other coil awg sizes available, consult factory.
- <sup>4</sup> Reference number of turns.

All specifications subject to change without notice.

- No shafts
- 3 tapped holes
- Return spring

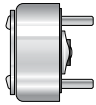

- Armature end shaft
- 3 tapped holes
- Return spring

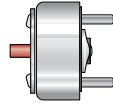

- Base end shaft
- 3 tapped holes
- Return spring

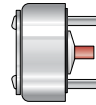

- Double shaft
- 3 tapped holes
- Return spring

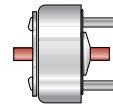

910-640-5XX  
910-645-5XX  
910-641-5XX  
910-646-5XX  
910-642-5XX  
910-647-5XX  
910-643-5XX  
910-648-5XX  
910-644-5XX  
910-649-5XX

910-490-5XX  
910-495-5XX  
910-491-5XX  
910-496-5XX  
910-492-5XX  
910-497-5XX  
910-493-5XX  
910-498-5XX  
910-494-5XX  
910-499-5XX

910-360-5XX  
910-365-5XX  
910-361-5XX  
910-366-5XX  
910-362-5XX  
910-367-5XX  
910-363-5XX  
910-368-5XX  
910-364-5XX  
910-369-5XX

910-280-5XX  
910-285-5XX  
910-281-5XX  
910-286-5XX  
910-282-5XX  
910-287-5XX  
910-283-5XX  
910-288-5XX  
910-284-5XX  
910-289-5XX

# Ledex® Rotary Solenoids 5B Dimensions

mm

## Armature Cover Configuration — Base End Shaft

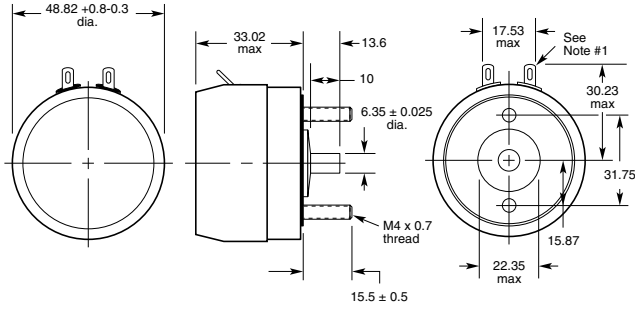

### Notes:

- 1) All configurations have solder lug terminals, 4.32 mm wide x 0.457 mm thick.
- 2) For electrical specs and performance charts, see pages D20-D21.

All specifications subject to change without notice.

ROTARY Solenoids

## No Shaft

3 holes equally spaced located 1/2 rotary stroke  $\pm 3^\circ$  to left of centre for R.H. stroke, right of centre for L.H. stroke. M3 x 0.5 thread

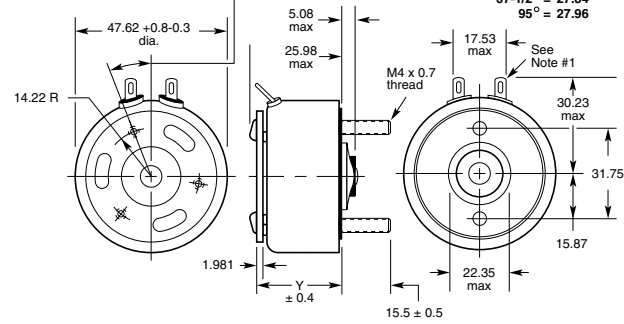

## Base End Shaft

3 holes equally spaced located 1/2 rotary stroke  $\pm 3^\circ$  to left of centre for R.H. stroke, right of centre for L.H. stroke. M3 x 0.5 thread

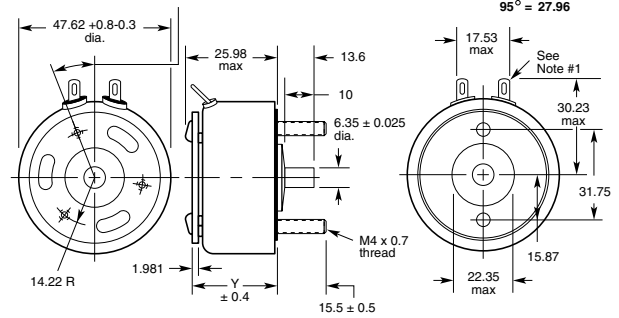

## Armature End Shaft

3 holes equally spaced located 1/2 rotary stroke  $\pm 3^\circ$  to left of centre for R.H. stroke, right of centre for L.H. stroke. M3 x 0.5 thread

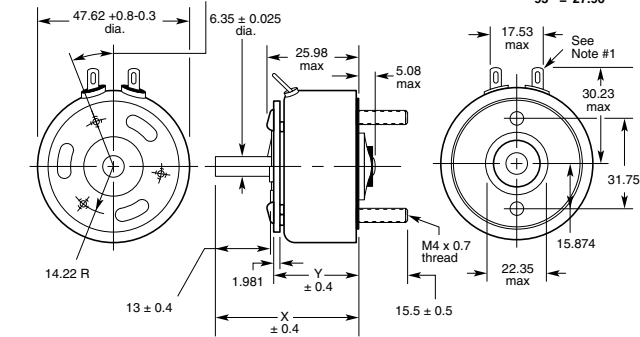

## Double Shaft

3 holes equally spaced located 1/2 rotary stroke  $\pm 3^\circ$  to left of centre for R.H. stroke, right of centre for L.H. stroke. M3 x 0.5 thread

