

Ledex® Rotary Solenoids Size 1E Precision Elongated Coil

Performance Specifications

Stroke	Holding Torque ² (mNm)	Starting Torque (mNm) ¹ @ 20°C Maximum Duty Cycle				
		100%	50%	25%	10%	5%
25°	31.64	*	22.6	45.2	90.4	124.3
35°	*	*	*	*	*	*
45°	16.95	*	11.3	22.6	45.2	67.8

All data is at 20°C coil temperature. Force (torque) outputs degrade with elevated temperatures.

¹ Gross starting torques are shown. For net available starting torque, subtract return spring torque of 6.8 mNm ±20%.

² Holding torque is shown at the stabilised temperature of 105°C and continuous duty.

* Consult factory.

● Well-suited for battery operation. See the "Battery Operated Solenoids" section for complete information.



All catalogue products manufactured after April 1, 2006 are RoHS Compliant

How to Order

- Using the Performance Chart to the left, select one of the five columns which provides the appropriate duty cycle for your application. Reading down this column locate the torque for the stroke you need. For net available starting torque, subtract return spring torque of 6.8 mNm ±20% (if torque is insufficient go to next larger solenoid size).
- Use the chart below to select the model number corresponding to your desired design, stroke and direction of rotation (as viewed from armature end, opposite mounting studs).
- Using the Specification Chart to the right, select the same duty cycle column. Follow down the column into the VDC ratings. Select the voltage which most closely matches your supply voltage. Read across to the left to select the coil awg suffix.
- Replace the last two digits of the model number (XX) with the coil awg number to complete the part number.

Please see www.ledex.com (click on Stock Products tab) for our list of stock products available through our distributors.

- Armature cover
- Armature end shaft
- Return spring

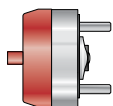

- Armature cover
- Base end shaft
- Return spring

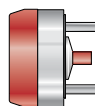

- Armature cover
- Double shaft
- Return spring

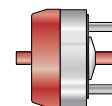

Stroke/ Direction*	Nom. Axial Stroke	Standard		Long Life		Standard		Long Life	
		Standard	Long Life	Standard	Long Life	Standard	Long Life	Standard	Long Life
25° CW	0.6 mm	M-1142-0XX	E-1142-0XX	M-1140-0XX	E-1140-0XX	M-15097-0XX	E-15097-0XX	M-3334-0XX	E-3334-0XX
25° CCW	0.6 mm	M-1145-0XX	E-1145-0XX	M-1144-0XX	E-1144-0XX	M-15207-0XX	E-15207-0XX	M-15208-0XX	E-15208-0XX
35° CW	0.8 mm	M-15201-0XX	E-15201-0XX	M-15205-0XX	E-15205-0XX	M-15207-0XX	E-15207-0XX	M-15208-0XX	E-15208-0XX
35° CCW	0.8 mm	M-15202-0XX	E-15202-0XX	M-15206-0XX	E-15206-0XX	M-15207-0XX	E-15207-0XX	M-15208-0XX	E-15208-0XX
45° CW	0.6 mm	M-1148-0XX	E-1148-0XX	M-1147-0XX	E-1147-0XX	M-15039-0XX	E-15039-0XX	M-15148-0XX	E-15148-0XX
45° CCW	0.6 mm	M-1150-0XX	E-1150-0XX	M-1149-0XX	E-1149-0XX	M-15039-0XX	E-15039-0XX	M-15148-0XX	E-15148-0XX

* Direction of rotation (cw – clockwise or ccw – counterclockwise) is viewed from the armature end of the solenoid opposite the mounting studs.

Note: The XX in the part number suffix must be filled in with the awg of your choice.

Ledex® Rotary Solenoids Size 1E Precision Elongated Coil

Coil Specifications

Maximum Duty Cycle	100%	50%	25%	10%	5%
Maximum ON Time (sec) when pulsed continuously ¹	∞	100	36	7	2.5
Maximum ON Time (sec) for single pulse ²	∞	162	44	8	2.8
Watts (@ 20°C)	*	10.5	21	54	108
Ampere Turns (@ 20°C)	*	492	695	1105	1560

Coil Data

avg (0XX) ³	Resistance (@20°C)	# Turns ⁴	VDC (Nom)	VDC (Nom)	VDC (Nom)	VDC (Nom)	VDC (Nom)
25	0.83	140	*	2.9	4.1	6.5	9.2
26	1.38	186	*	3.7	5.2	8.2	11.6
27	1.91	210	*	4.5	6.3	10.1	14.2
28	3.17	273	*	5.7	8.1	12.8	18.1
29	5.17	352	*	7.2	10.2	16.2	23.0
30	8.25	441	*	9.2	13.0	21.0	29.0
31	12.95	550	*	11.6	16.4	26.0	37.0
32	20.71	682	*	14.9	21.0	34.0	47.0
33	30.60	828	*	18.2	26.0	41.0	58.0
34	50.95	1078	*	23.0	33.0	52.0	74.0
35	83.92	1392	*	30.0	42.0	67.0	94.0

General Specifications

Dielectric Strength	1000 VRMS, all coils
Recommended Minimum Heat Sink	Maximum watts dissipated by solenoid are based on an unrestricted flow of air at 20°C, with solenoid mounted on the equivalent of an aluminium plate measuring 76.2 mm square by 3.2 mm thick.
Coil Resistance	±5% tolerance
Starting Torque	Gross torque values are shown. For net starting torque, subtract return spring torque
Return Spring Torque	6.8 mNm ±20%
Weight	42.5 g
Dimensions	See page D28

- ¹ Continuously pulsed at stated watts and duty cycle.
 - ² Single pulse at stated watts (with coil at ambient room temperature 20°C).
 - ³ Other coil avg sizes available, consult factory.
 - ⁴ Reference number of turns.
- * Consult factory.

All specifications subject to change without notice.

- No shafts
- 3 tapped holes
- Return spring

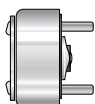

- Armature end shaft
- 3 tapped holes
- Return spring

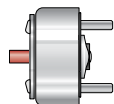

- Base end shaft
- 3 tapped holes
- Return spring

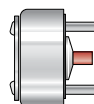

- Double shaft
- 3 tapped holes
- Return spring

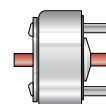

ROTARY Solenoids

Standard		Long Life		Standard		Long Life		Standard		Long Life	
M-1143-0XX	E-1143-0XX	M-15089-0XX	E-15089-0XX	M-15211-0XX	E-15211-0XX	M-15215-0XX	E-15215-0XX	M-15216-0XX	E-15216-0XX	M-15217-0XX	E-15217-0XX
M-1146-0XX	E-1146-0XX	M-3311-0XX	E-3311-0XX	M-15084-0XX	E-15084-0XX	M-15216-0XX	E-15216-0XX	M-15217-0XX	E-15217-0XX	M-15218-0XX	E-15218-0XX
M-15200-0XX	E-15200-0XX	M-15204-0XX	E-15204-0XX	M-15212-0XX	E-15212-0XX	M-1305-0XX	E-1305-0XX	M-15217-0XX	E-15217-0XX	M-15218-0XX	E-15218-0XX
M-15203-0XX	E-15203-0XX	M-15210-0XX	E-15210-0XX	M-15213-0XX	E-15213-0XX	M-15217-0XX	E-15217-0XX	M-15218-0XX	E-15218-0XX	M-15219-0XX	E-15219-0XX
M-1141-0XX	E-1141-0XX	M-3380-0XX	E-3380-0XX	M-15085-0XX	E-15085-0XX	M-15218-0XX	E-15218-0XX	M-15218-0XX	E-15218-0XX	M-15219-0XX	E-15219-0XX
M-1151-0XX	E-1151-0XX	M-1282-0XX	E-1282-0XX	M-15214-0XX	E-15214-0XX	M-15219-0XX	E-15219-0XX	M-15219-0XX	E-15219-0XX	M-15219-0XX	E-15219-0XX

Ledex® Rotary Solenoids 1E Dimensions

mm

Armature Cover Configuration — Armature End Shaft

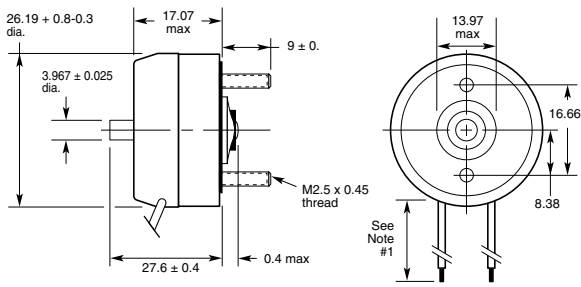

Armature Cover Configuration — Base End Shaft

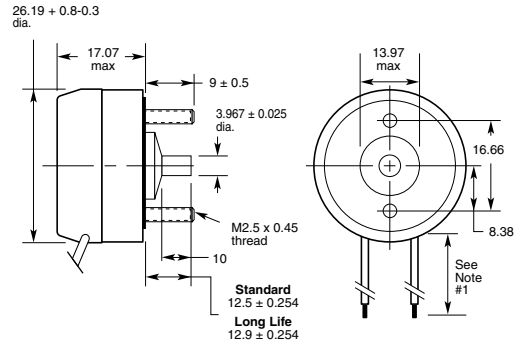

Armature Cover Configuration — Double Shaft

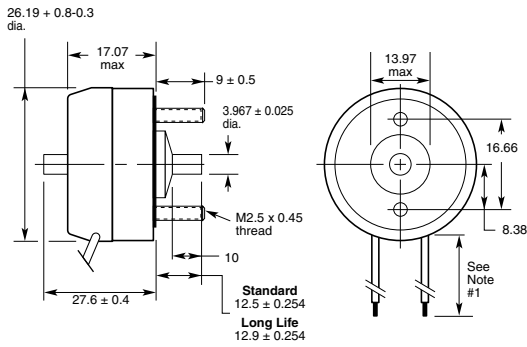

Notes:

- 1) All configurations have 250 mm minimum leads, 24 awg, PVC insulation.
- 2) For electrical specs and performance charts, see pages D10-D11.

All specifications subject to change without notice.

No Shaft

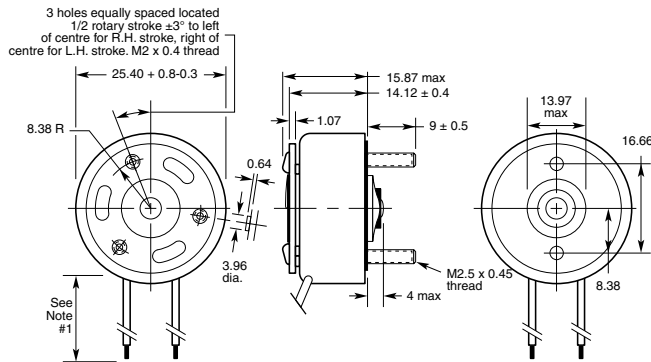

Base End Shaft

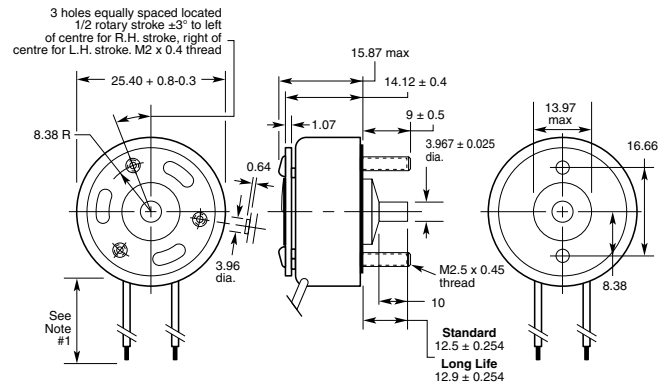

Armature End Shaft

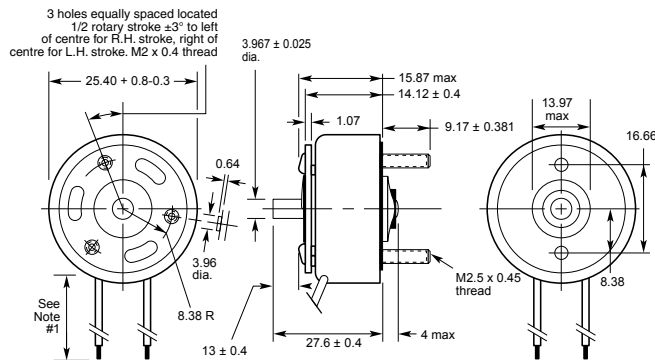

Double Shaft

